

POMPA MONOVITE

PMT 80-120-180-250-300



Mori[®]
IMPIANTI ENOLOGICI

 Pompa monovite con tramoggia atta al trasferimento di uva intera, diraspata e vinaccia fermentata.

Realizzata completamente in acciaio inox aisi 304. Su ruote 2 fisse e 2 girevoli con freno. Ampia tramoggia di carico. Scarico totale del liquido. Rotore in acciaio inox aisi 304. Statore in gomma speciale alimentare. Uscita d. 80/100/120. Quadro di comando pompa con invertitore di marcia.

A richiesta: inverter elettronico per variazione velocità, sonde controllo livello in tramoggia.

 Pompe mono-vis avec trémie conçue pour le transport de raisin entier, égrappé et du marc fermenté.

Fabriquée entièrement en acier inox AISI 304. Sur deux roues fixes et deux roues pivotantes avec frein. Large trémie de chargement. Décharge totale du liquide. Rotor en acier inox AISI 304. Stator en caoutchouc spécial alimentaire. Sortie d. 80/100/120. Tableau de commande pompe avec inverseur de marche.

Sur demande: inverter électronique pour la variation de la vitesse, sondes de contrôle du niveau à l'intérieur de la trémie.

 Single screw pump with hopper suitable for the transfer of whole and destalked grapes and fermented marc.

AISI-304 stainless steel construction. On 2 fixed wheels and 2 swivelling wheels with brake. Large loading hopper. Complete discharge of the liquid. AISI-304 stainless steel rotor. Stator made from special rubber for food contact. Exit d. 80/100/120. Pump control panel with reversing gear.

On request: electronic inverter for speed variation, level control probes inside the hopper.

 Einzelschraubenpumpe mit Ladetrichter für das Umfüllen ganzer und abgebeelter Trauben und von fermentiertem Trester.

Vollständig aus Edelstahl AISI 304 gefertigt. Auf Rädern, 2 feste und 2 schwenkbare mit Bremsen. Grosser Ladetrichter. Vollständiges Entleeren der Flüssigkeit. Rotor aus Edelstahl AISI 304. Stator aus speziellem Gummi für den Nahrungsmittelkontakt. Ausgang D. 80/100/120. Pumpen Steuertafel mit Umsteuerungsvorrichtung.

Auf Anfrage: elektronischer Inverter für Geschwindigkeitsänderung, Niveausonden im Ladetrichter.

 Bomba monotornillo con tolva indicada para el trasiego de uvas enteras, despalladas y orujo fermentado.

Realizada completamente en acero inoxidable aisi 304. Sobre ruedas, 2 fijas y 2 giratorias con frenos. Amplia tolva de carga. Descarga total del líquido. Rotor de acero inoxidable aisi 304. Estator de goma especial alimentaria. Salida d. 80/100/120. Cuadro de control bomba con inversor de marcha.

A petición: inversor electrónico de variación de velocidad, sondas control de nivel en la tolva.

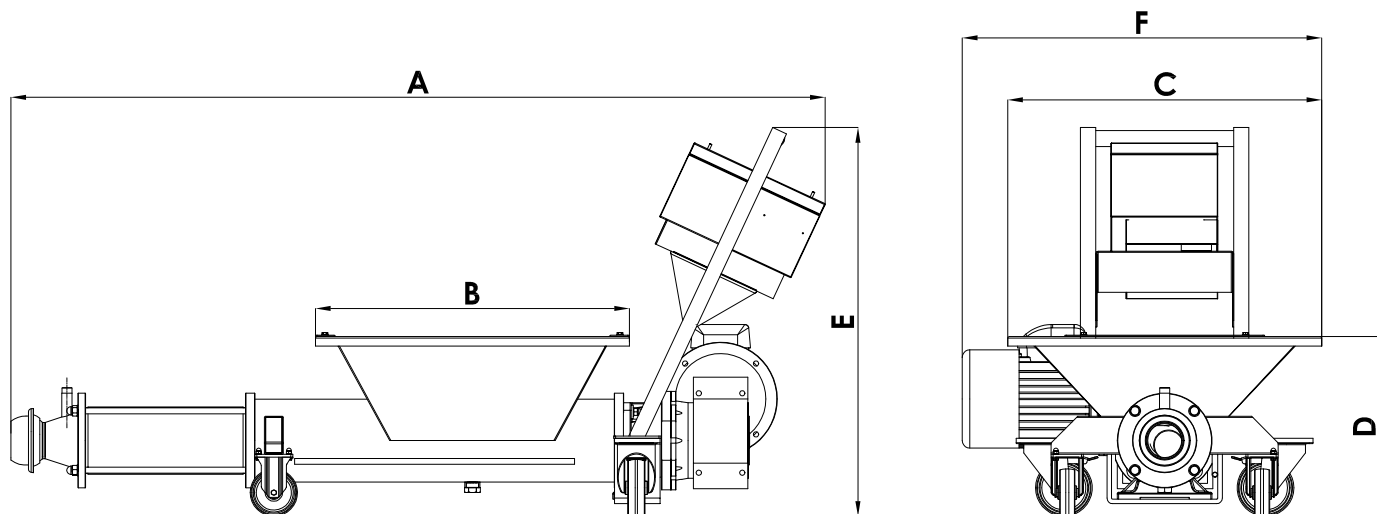

TIPO TYPE TYPE TYP TIPO	MOTORE MOTEUR MOTOR MOTORLEISTUNG MOTOR	VELOCITÀ VITESSE SPEED GESCHWINDIGKET VELOCIDAD	PORTATA DEBIT DELIVERY FÖRDERMENGE CAUDAL	RACCORDI RACCORDS FITTINGS ANSCHLÜSSE RACORES	DIMENSIONI DIMENSIONS DIMENSIONS MASSE MEDIDAD A - B - C - D - E - F	PESO POIDS WEIGHT GEWICHT PESO
PMT 80	kW. 3,0 V. 400	70-200	Ton/h. 6-8	D. 80	1900-700-700-420-1000-800	Kg. 130
PMT 120	kW. 4,0 V. 400	70-200	Ton/h. 10-12	D. 100	2100-830-830-420-1030-900	Kg. 150
PMT 180	kW. 5,5 V. 400	70-200	Ton/h. 16-18	D. 120	2160-830-830-475-1030-950	Kg. 210
PMT 250	kW. 7,5 V. 400	70-200	Ton/h. 20-25	D. 120	2200-830-830-475-1030-980	Kg. 270
PMT 300	kW. 9,2 V. 400	70-200	Ton/h. 25-30	D. 120	2630-1160-1010-475-1080-1070	Kg. 300

Mori
IMPIANTI ENOLOGICI

MORI LUIGI s.r.l. - Via Cassia, 42 - Fraz. Calzaiolo - 50026 SAN CASCIANO VAL DI PESA (FI)
Tel. +39 055 8249117 Fax +39 055 8249304 - www.moriluigi.it - E-mail: mori@moriluigi.it

Dati e misure non sono impegnativi e possono essere variati senza preavviso